

HINGE SCREWS

CYLINDRICAL HEAD STAR

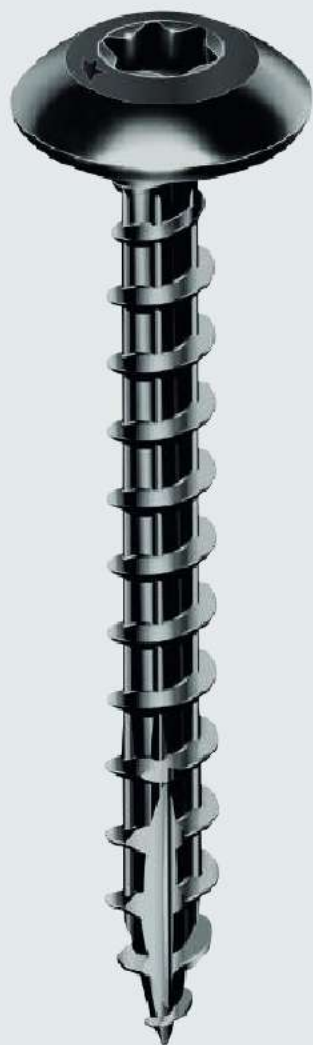
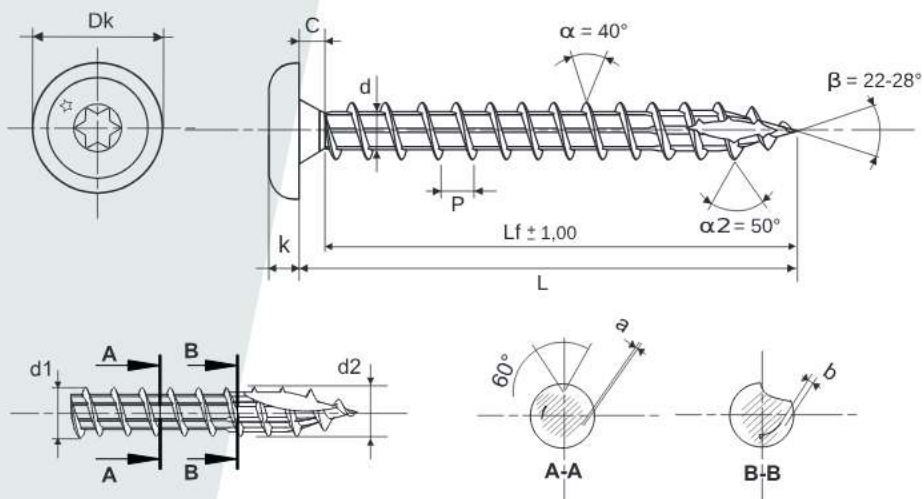

TECHNICAL CHARACTERISTICS

	ø 6	ø 7
Head depth	2,10 / 2,50	2,10 / 2,50
Screw driver	TX 30	TX 30
Dk	13,87 / 14,55	13,87 / 14,55
C	1,00 / 2,50	1,00 / 2,50
k	3,00 / 3,40	3,00 / 3,40
d	3,65 / 4,10	4,10 / 4,60
P	3,50 ± 10%	3,70 ± 10%
d1	5,80 / 6,10	6,80 / 7,10
d2	6,05	7,05
a/b	0,22 / 0,45	0,25 / 0,48
Minimum breaking torque	11,50 Nm	17,00 Nm

All Ø	30/70
Tolerance	- 1,25

Black-zinc-coated steel - Bichromate steel